

■ **Features**

- Highest luminous flux
- Super energy efficiency
- Long lifetime operation
- Superior UV Resistance

■ **Applications**

- Read lights (car, bus, aircraft)
- Portable (flashlight, bicycle)
- Bollards / Security / Garden
- Traffic signaling / Beacons
- In door / Out door Commercial lights
- Automotive Ext

■ **Absolute Maximum Rating**





(Ta=25°C)

Item	Symbol	Value		Unit
		W/M/B/PG	Y/R	
DC Forward Current	I _F	150	150	mA
Pulse Forward Current#	I _{FP}	200	200	mA
Reverse Voltage	V _R	5	5	V
Power Dissipation	P _D	540	390	mW
Operating Temperature	Topr	-30 ~ +85		°C
Storage Temperature	Tstg	-40 ~ +100		°C
Lead Soldering Temperature	Tsol	260°C/10sec		-

#Pulse width Max.10ms Duty ratio max 1/10

■ **Electrical -Optical Characteristics**

(Ta=25°C)

Part Number	Color			V _F (V)			I _R (μA)	Φv(lm)*			CCT(K)\Wd(nm)*			2θ1/2(deg)
				Min.	Typ.	Max.		Max.	Min.	Typ.	Max.	Min.	Typ.	
				I _F =150mA			I _F =150mA			V _R =5V			I _F =150mA	
OSW43535C1A-150mA	White	W		3.0	3.2	3.6	10	45	55	-	CCT:5800~7000K			120
OSM53535C1A-150mA	Warm White	M		3.0	3.2	3.6	10	45	55	-	CCT:2700~3500K			120
OSB53535C1A-150mA	Blue	B		3.0	3.2	3.6	10	6	10	-	460	465	470	120
OSG53535C1A-150mA	Pure Green	PG		3.0	3.2	3.6	10	20	25	-	515	520	525	120
OSY53535C1A-150mA	Yellow	Y		1.8	2.2	2.6	10	10	15	-	585	590	595	120
OSR53535C1A-150mA	Red	R		1.8	2.2	2.6	10	15	20	-	620	625	630	120

*1 Tolerance of measurements of chromaticity coordinate is ±10%

*2 Tolerance of measurements of dominant wavelength is ±1nm

*3 Tolerance of measurements of luminous flux is ±15%

*4 Tolerance of measurements of forward voltage is ±0.1V

*5. Don't drive at rated current more than 5s without heat sink for Power Top H emitter series.

■ **Outline Dimension**

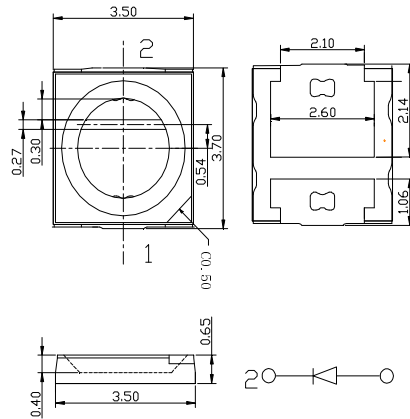

Recommended Soldering Patter

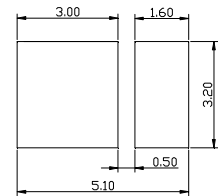

Unit:mm
Tolerance:±0.20mm
unless otherwise noted

■ **Directivity**

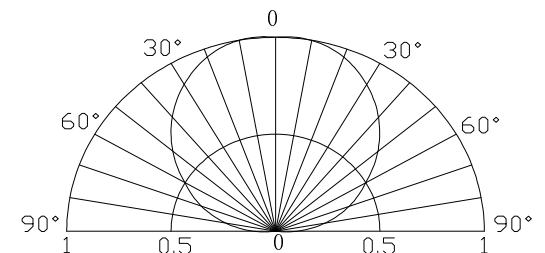

■ Soldering Conditions

Reflow Soldering		Hand Soldering	
Pre-Heat	180 ~ 200°C	Temperature Soldering time	350°C Max. 3 sec. Max. (one time only)
Pre-Heat Time	120 sec. Max.		
Peak temperature	260°C Max.		
Dipping Time	10 sec. Max.		
Condition	Refer to Temperature-profile		

• Reflow Soldering Condition(Lead-free Solder)

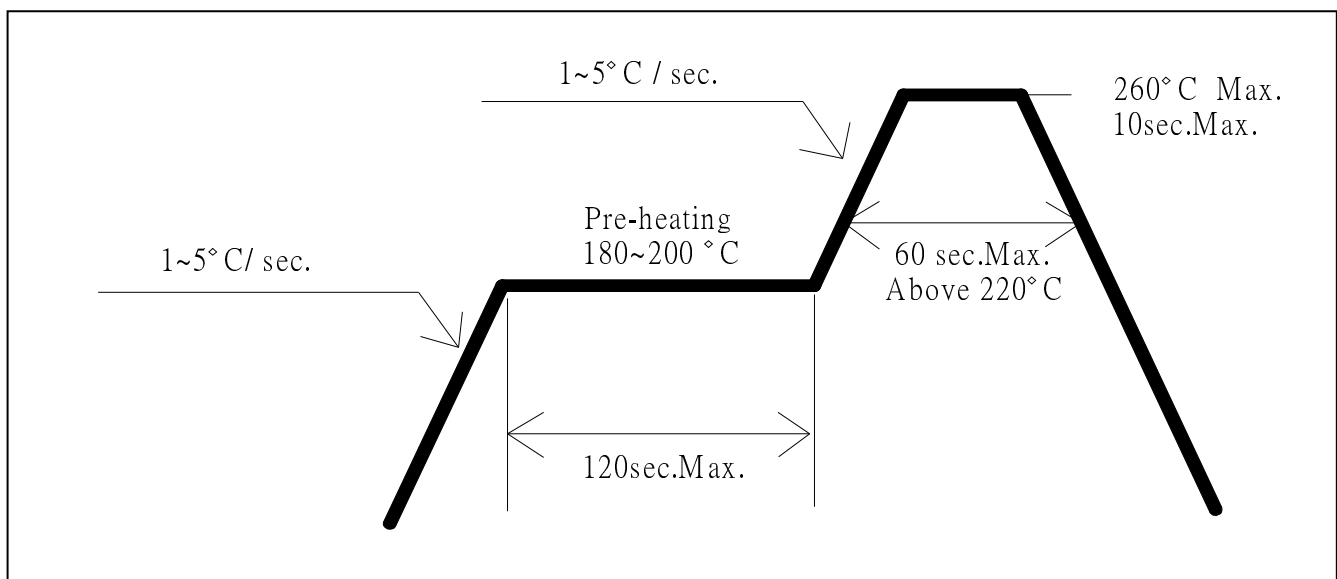

*Recommended soldering conditions vary according to the type of LED

*Although the recommended soldering conditions are specified in the above table, reflow, or hand soldering at the lowest possible temperature is desirable for the LEDs.

*A rapid-rate process is not recommended for cooling the LEDs down from the peak temperature.

- All SMD LED products are pb-free soldering available.
- Occasionally there is a brightness decrease caused by the influence of heat or ambient atmosphere during air reflow. It is recommended that the User use the nitrogen reflow method.
- Repairing should not be done after the LEDs have been soldered. When repairing is unavoidable a double-head soldering iron should be used. It should be confirmed beforehand whether the characteristics of the LEDs will or will not be damaged by repairing.
- Reflow soldering should not be done more than two times.
- When soldering, do not put stress on the LEDs during heating.
- After soldering, do not warp the circuit board.

PACKING

Tape leader and reel (2000pcs/Reel)

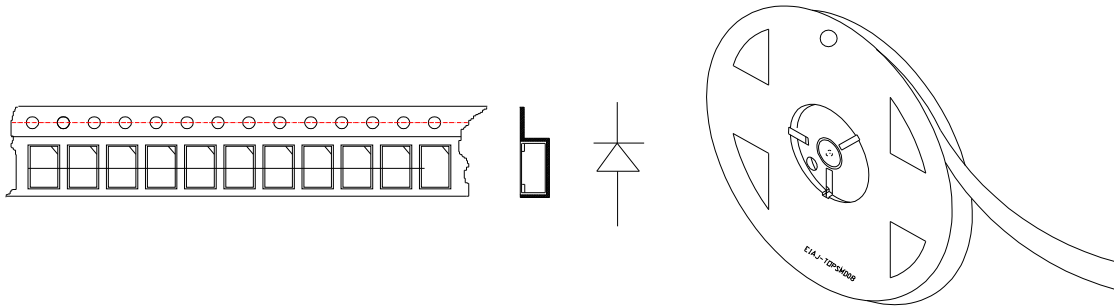

Moisture Resistant Packing

