

■Features

- Miniature size
- Built-in exclusive IC
- Wide half angle & long reception distance
- Good noise-proof capability
- High immunity against ambient light
- Back Matel Cover
- Side view / Mesh
- ESD Grade:Class2(<2.5KV)

■Applications

- AV instruments (Audio, TV, VCR, CD player)
- Home appliances (Air-conditioner, Fan, Light.)
- Remote control for wireless devices

■Absolute Maximum Rating (Ta=25°C)

Parameter	Symbol	Ratings	Unit
Supply Voltage	V _{cc}	6.0	V
Operating Temperature	Topr	-10 ~ +60	°C
Storage Temperature	Tstg	-20 ~ +75	°C
Lead Soldering Temperature *1	Tsol	260°C	-

*1 At the position of 2mm from the bottom of the package within 5 seconds

■Electrical -Optical Characteristics (Ta=25°C)

Item	Symbol	Condition	Min.	Typ.	Max.	Unit
Supply Voltage	V _{cc}		2.7	3.0	5.5	V
Current Consumption	I _{cc}	Input signal=0	-	0.9	1.5	mA
Reception Distance	d	200±5Lux, V _{cc} =3V	-	20	-	m
B.P.F. Center Frequency	F _o		-	37.9	-	KHZ
Peak Wavelength	λ _p		-	940	-	nm
Signal Output	So		--Active Low--			
High level output voltage	V _{oh}	V _{cc} =3V	2.7	3.0		V
		V _{cc} =5V	4.7	5.0		V
Low level output voltage	V _{ol}	V _{in} =0V I _{sink} =2.0mA	-	0.2	0.4	V
Burst width tolerance *2	Bw	Burst Wave=600μs	400	600	800	μs
Half Angle	Δθ			90		deg

*2 The output tolerance of burst width received when transmitter sends the burst wave.

■Outline Dimension

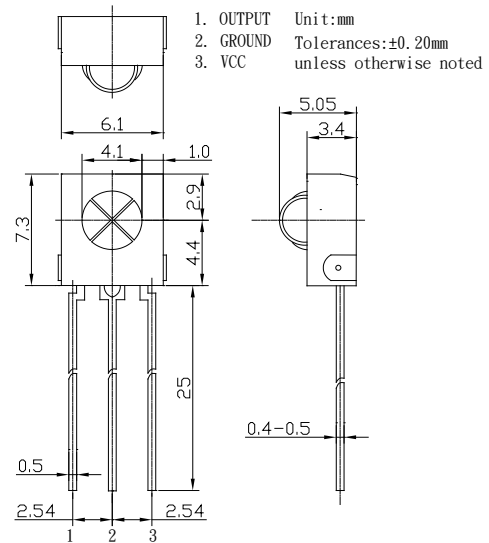

■Directivity

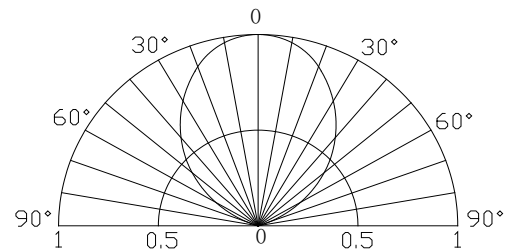

■ Carrier Frequency

Relative Reception Distance vs Transmitter carrier Frequency

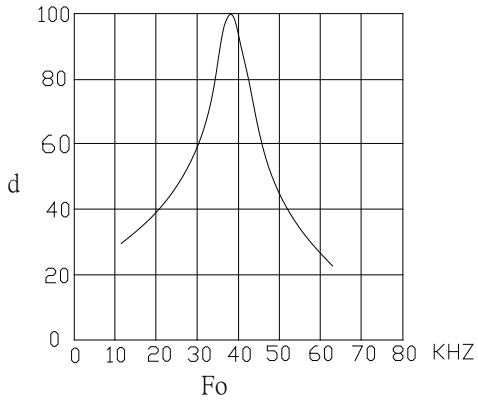

■ For Noisy Power Supply

In case of noisy power supply, please serially insert 100Ω resistor and about 47μF electrolytic capacitor in Vcc line and ground as follows:

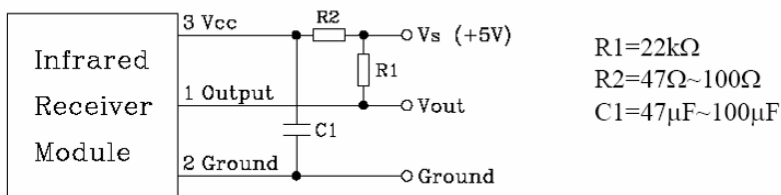

■ Block Diagram

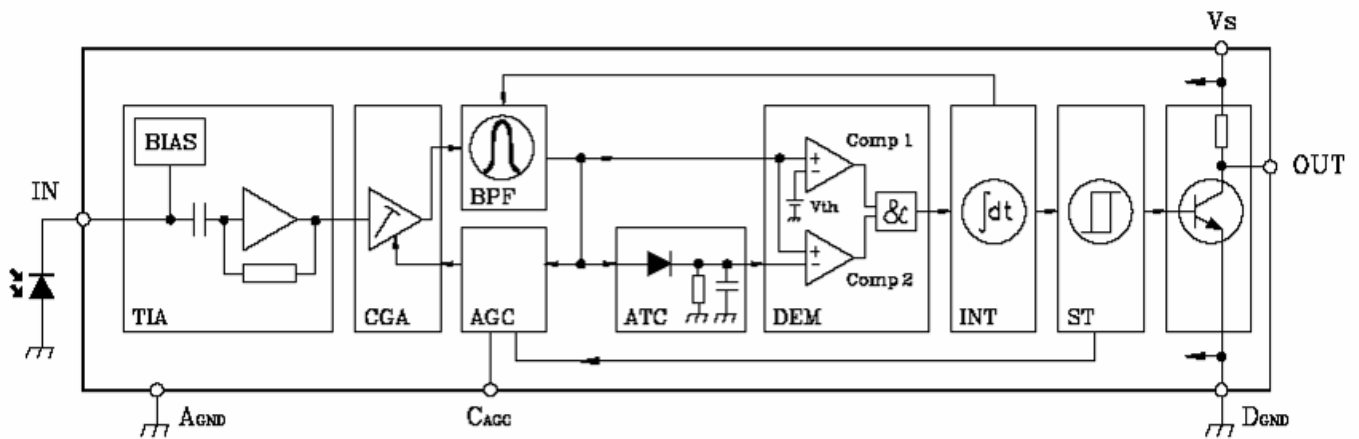

TIA Transimpedance amplifier
 CGA Controlled gain amplifier
 BPF Bandpass filter
 AGC Automatic gain control

ATC Automatic threshold control
 DEM Demodulator
 INT Integrator
 ST Schmitt trigger

■ Testing Method

Distance between emitter and detector specifies maximum distance that output waveform satisfies the standard (FIG-3) under the standard transmitter.

a. Measuring place

Indoor Without extreme reflection of light.

b. Ambient light source

Detecting surface illumination is 200 ± 5 Lux under ordinary white fluorescence lamp of no high frequency lightning.

c. Standard transmitter

Transmitter wave indicated in FIG-2 of standard transmitter is arranged to satisfy $V_o \geq 50mV_{p-p}$ under the measuring circuit specified in FIG-3

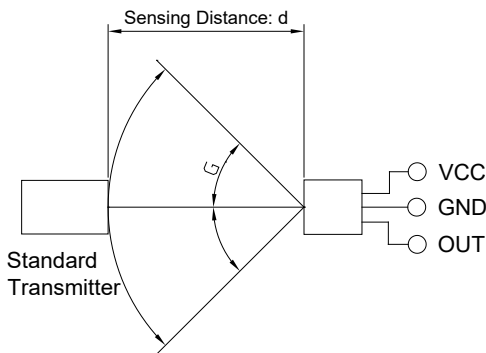

FIG-1

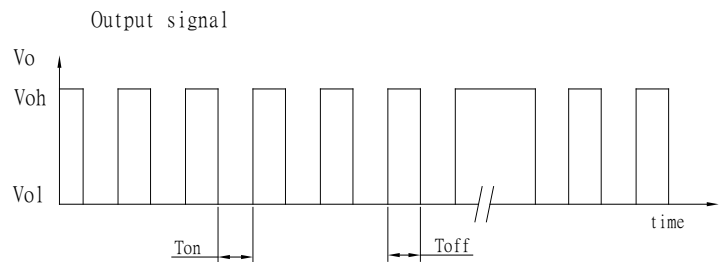
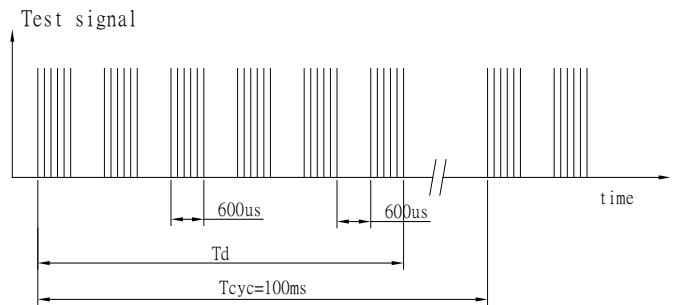

FIG-2

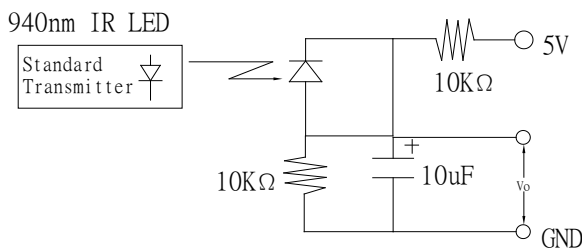

FIG-3 Power Output Measurement Circuit

■ Precautions for Use

- Store and use where there is no force causing transformation or change in quality.
- Store and use where there is no corrosive gas or sea(salt) breeze.
- Store and use where there is no extreme humidity.
- Solder the lead pin within the condition of ratings. After soldering, do not add exterior force.
- Do not wash this device. Wipe the stains of diode side with a soft cloth. You can use the solvent, ethyl alcohol, or methyl alcohol only.
- To prevent static electricity damage to the pre-amp, make sure that the human body, the soldering iron are connected to ground before using.

LAMP PACKING

250pcs/Bag

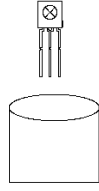

LED LAMPS	
PART NO:	_____
LOT NO:	_____
IV:	_____
VF:	_____
COLOR:	_____
QTY:	_____
QC:	_____

BOX

Dimension (mm)
396*305*324
40Bags/Box

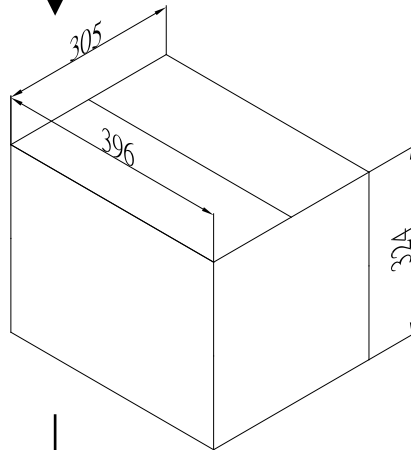

Carton

Dimension (mm)
675*410*320
2Boxes/Carton

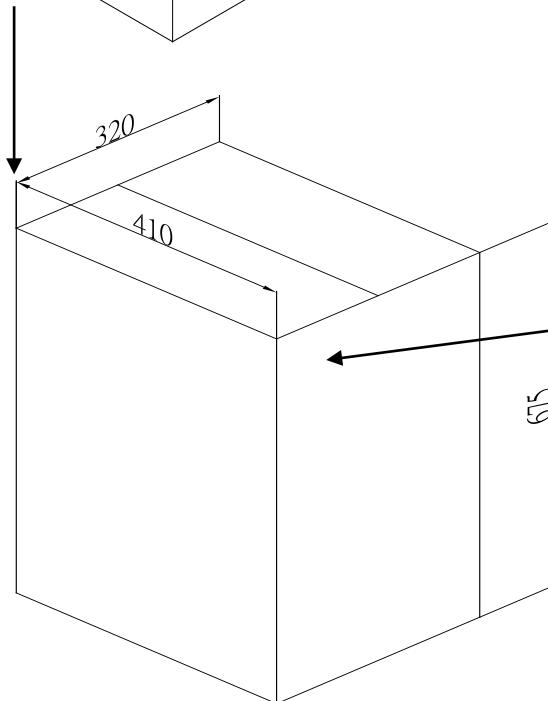

LED LAMPS	
PART NO:	_____
LOT NO:	_____
IV:	_____
VF:	_____
COLOR:	_____
QTY:	_____
QC:	_____

(1)Storage

• The **Infrared Receiver Modules** should be stored at 30°C or less and 70%RH or less after being shipped from Optosupply and the storage life limits are 3 months. If the **Infrared Receiver Modules** are stored for 3 months or more, they can be stored for a

year in a sealed container with a nitrogen atmosphere and moisture absorbent material.

• Optosupply's **Infrared Receiver Modules** leadframes are silver plated Fe or Copper alloy. The silver surface may be affected

by environments which contain corrosive substances. Please avoid conditions which may cause **Infrared Receiver Modules** to

corrode, tarnish or discolor. This corrosion or discoloration may cause difficulty during soldering operations.

It is recommended that the **Infrared Receiver Modules** be used as soon as possible.

• Please avoid rapid transitions in ambient temperature, especially, in high humidity environments where condensation can occur.